



Jacuzzi® Item / Produit Jacuzzi® / Artículo de jacuzzi® #: PQ30827(Chrome) / PQ30826(Brushed Nickel) / PQ30845(Oil Rubbed Bronze)

60"- 72" ALUMINUM CURVED ROD
60"- 72" BARRA CURVADA DE ALUMINIO
60"- 72" TIGE COURBÉE EN ALUMINIUM

Questions, problems, missing parts? Before returning to your retailer, call our customer service department at 1-800-288-4002, 9 a.m. - 8 p.m., EST, Monday - Friday.

Des questions, des problèmes, des pièces manquantes? Avant de retourner l'article au détaillant, appelez notre service à la clientèle au 1 800 288-4002, entre 9 h et 20 h (HNE), du lundi au vendredi.

¿Preguntas, problemas, piezas faltantes? Antes de volver a la tienda, llame a nuestro Departamento de Servicio al Cliente al 1-800-288-4002, de lunes a viernes de 9 a.m. a 8 p.m., hora estándar del Este.

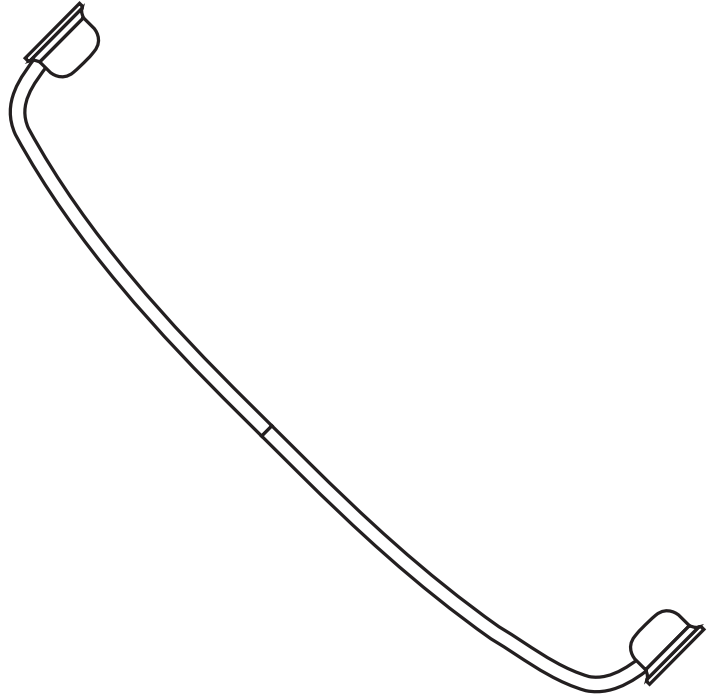

**ATTACH YOUR RECEIPT HERE /
JOIGNEZ VOTRE REÇU ICI /
ADJUNTE SU RECIBO AQUÍ**

**Serial Number / Numéro de série /
Número de serie** _____

**Purchase Date / Date d'achat /
Fecha de compra** _____



SAFETY INFORMATION / CONSIGNES DE SÉCURITÉ / INFORMACIÓN DE SEGURIDAD

Please read and understand this entire manual before attempting to assemble, operate, or install the product.

Assurez-vous de lire et de comprendre l'intégralité de ce manuel avant de tenter d'assembler, d'installer ou d'utiliser le produit.

Lea y comprenda completamente este manual antes de intentar ensamblar, usar o instalar el producto.

WARNING / AVERTISSEMENT / ADVERTENCIA:

- Follow the installation instructions carefully. Proper installation is the installer's responsibility.
- Suivez attentivement les instructions pour l'installation. Il incombe à l'installateur d'effectuer une installation adéquate.
- Siga atentamente las instrucciones de instalación. El instalador tiene la responsabilidad de realizar una instalación adecuada.

PREPARATION / PRÉPARATION / PREPARACIÓN

Before beginning the assembly of this product, make sure all parts are present. Compare parts with the package contents and hardware contents list. If any part is missing or damaged, do not attempt to assemble the product.

Avant de commencer l'assemblage du produit, assurez-vous d'avoir toutes les pièces. Comparez le contenu de l'emballage avec la liste des pièces et celle de la quincaillerie. S'il y a des pièces manquantes ou endommagées, ne tentez pas d'assembler le produit.

Antes de comenzar el ensamblaje del producto, asegúrese de tener todas las piezas. Compare las piezas con la lista del contenido del paquete y el diagrama. No intente ensamblar el producto si falta alguna pieza o si estas están dañadas.

Tools Required/Outils requis/Herramientas requeridas
Not included / Non Inclus / No Incluidas

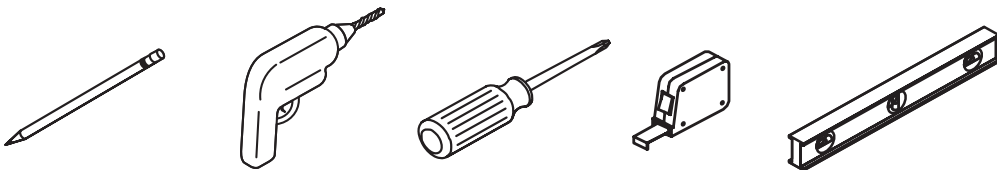



Parts Supplied/Pièces fournies/Piezas provistas

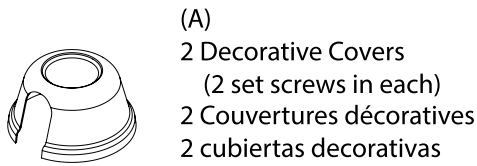

(A)
 2 Decorative Covers
 (2 set screws in each)
 2 Couvertures décoratives
 2 cubiertas decorativas

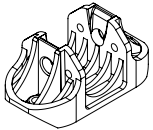

(B)
 1 in. Mounting Bracket
 1 po Support de montage
 1 en soporte de montaje

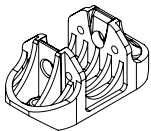

(C)
 7/8 in. Mounting Bracket
 Support de montage 7/8 po
 Soporte de montaje de 7/8 pulg.



(D)
 2 Pin Screw
 2 broches
 Tornillo de 4 clavijas



(E)
 4 Mounting Screws
 4 Vis de montage
 4 Tornillos de montaje



(F)
 4 Wall Anchor
 4 Ancres de mur
 4 Anclaje de pared



(G)
 4 Set Screws
 4 Vis de réglage
 4 Tornillos de fijación



(H)
 1 Transition Ring
 1 anneau de transition
 1 anillo de transición



(I)
 1 Allen Wrench
 1 llave Allen
 1 llave Allen

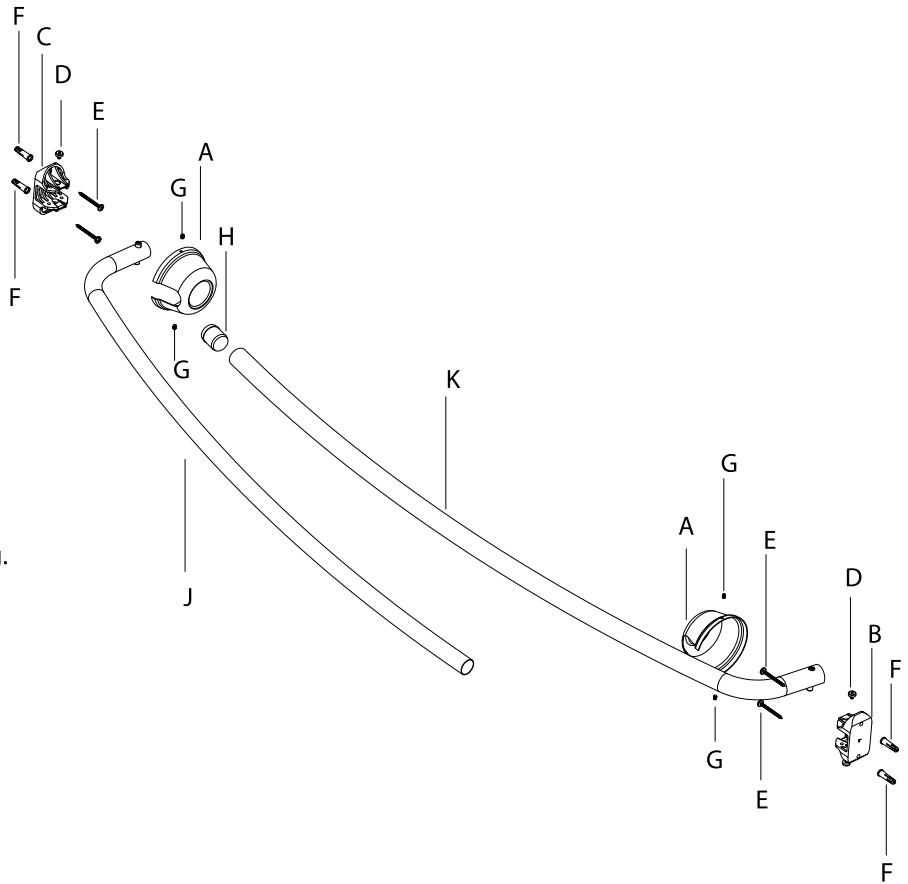

(J)
 1 in. Diameter Tube
 Tubos de diámetro de 1
 Tubes de 25.4 mm (1 po)
 de diamètre

(K)
 7/8 in. Diameter Tube
 Tubos de diámetro de 7/8
 Tubes de 22 mm (7/8 po)
 de diamètre

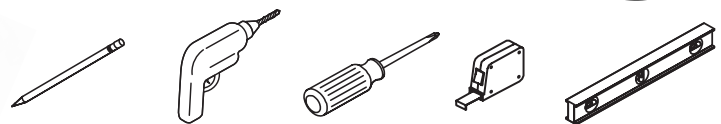

Tools Required/Outils requis/Herramientas requeridas

- 1 Measure up 65 in. above the front of the tub ledge. Draw 2" vertical line down

Mesurer jusqu'à 65 po au-dessus de l'avant du rebord de la cuve. Dessiner 2" verticale ligne vers le bas.

Mida hasta 65 pulgadas por encima de la parte frontal del reborde de la bañera. Dibujar 2" Línea vertical abajo

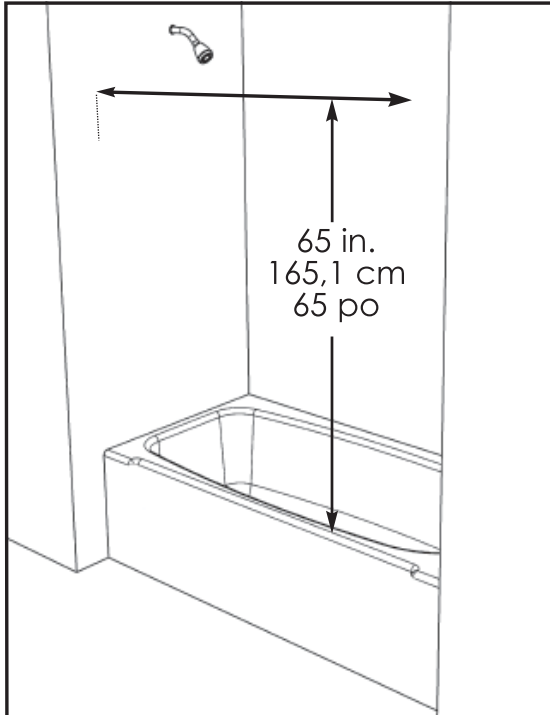

- 2 Hold the 1 in. mounting bracket (B) against the wall so that the mark is centered in the top screw hole. Mark the location of both holes. Repeat using 7/8 in. bracket (C) on other side.

Tenez le support de montage de 1 po (B) contre le mur pour Est centrée dans le trou de vis supérieur. Marquez l'emplacement des deux des trous. Répétez l'opération en utilisant le support 7/8 (C) de l'autre côté

Sujete el soporte de montaje de 1 pulg. (B) contra la pared para La marca está centrada en el orificio de tornillo superior. Marque la ubicación de ambos Agujeros Repita usando el soporte 7/8 (C) en el otro lado

Mark Hole Location
 Mark Hole Emplacement
 Mark Hole Localización

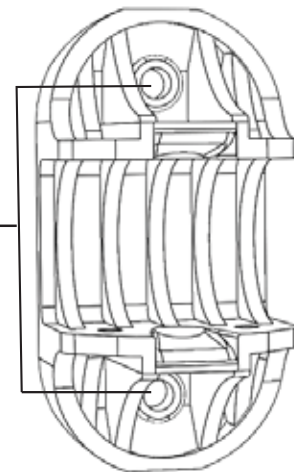

- 3 Drill the 2 marked spots for each mounting bracket. Insert drywall anchors (F) in the holes (unless screw will go directly into a stud).

Perçer les 2 taches marquées pour chaque support de montage. Insérer (P) dans les trous (à moins que la vis ne passe directement Dans un montant).

Taladre los 2 puntos marcados para cada soporte de montaje. Insertar (P) en los orificios (a menos que el tornillo salga directamente En un tallo).

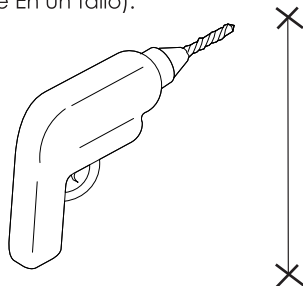

Note: use a 9/32 inch (7mm) drill bit for drywall anchor installation. Use a 5/64 inch (2mm) drill bit for direct stud installation.

Remarque: utilisez le foret de 9/32 pouces (7mm) pour l'installation de l'ancrage de panneaux sèches. Utilisez un foret de 5/64 pouces (2mm) pour l'installation directe des poteaux.

Nota: utilice una broca de 9/32 pulgadas (7 mm) para la instalación del anclaje de paneles de yeso. Utilice una broca de 5/64 pulgadas (2 mm) para la instalación directa de espárragos.

- 4 Fasten both 1" mounting bracket (B) and 7/8" mounting bracket (C) to the wall, using 2 mounting screws (E) each.

Fixez le support de montage de 1 "(B) et le support de montage de 7/8" (C) Au mur, en utilisant deux grandes vis (E) chacune.

Sujete tanto el soporte de montaje de 1 "(B) como el soporte de montaje de 7/8" (C) A la pared, usando 2 tornillos grandes (E) cada uno.

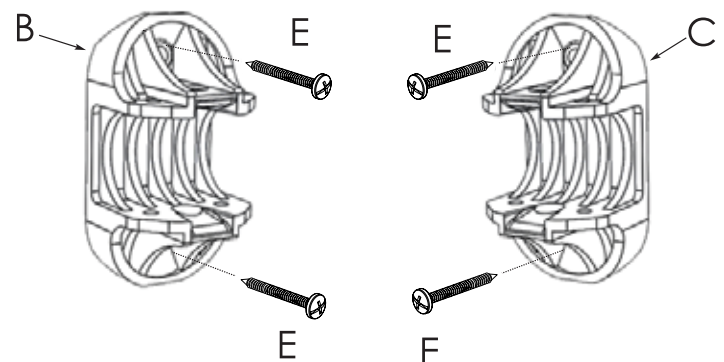

5 Insert transition ring (H) into the end of the 1 in. diameter tube (J), as shown. Insert the end of the 7/8 in. tube (K) into the end of the 1 in. diameter tube (J), as shown. Extend the tubes to the proper length to fit between the mounting brackets (B,C).

Insérer la bague de transition (H) dans l'extrémité du tube de diamètre 1 po (J), comme montré. Insérez l'extrémité du tube de 7/8 po (K) à l'extrémité du Tube de 1 po de diamètre (J), tel qu'illustré. Étendre les tubes à la bonne Longueur entre les supports de montage (B, C).

Inserte el anillo de transición (H) al final del diámetro (J), como se muestra. Inserte el extremo de los 7/8 pulg. (K) al final del Diámetro del tubo (J) de 1 pulg., Como se muestra. Extender los tubos a la Longitud entre los soportes de montaje (B, C).

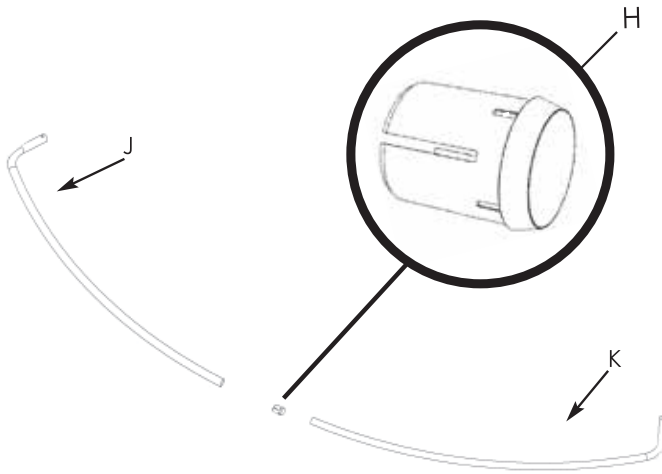

6 Align 1" rod(J) pins to center of bracket(B), compress pins and slide into 1 in. mounting bracket (B) until pins open. Repeat same on 7/8" side (K) (C).

Alignez les tiges de 1 "(J) au centre du support (B), compressez les broches et faites glisser Dans le support de montage (B) jusqu'à ce que les broches soient ouvertes. Répétez l'opération sur le côté 7/8 "(K) (C).

Alinee los pernos de varilla de 1 "(K) al centro del soporte (B), comprima los pernos y deslice En el soporte de montaje (B) hasta que los pasadores se abran. Repita el mismo en 7/8 "lado (L) (C)

1 in. Side

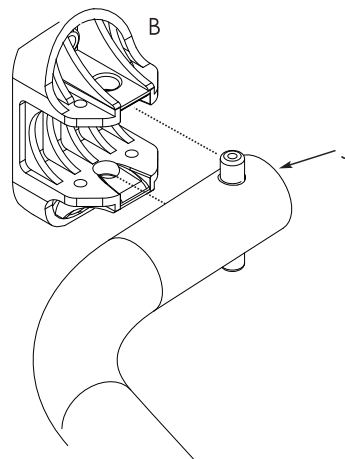

7/8 in. Side

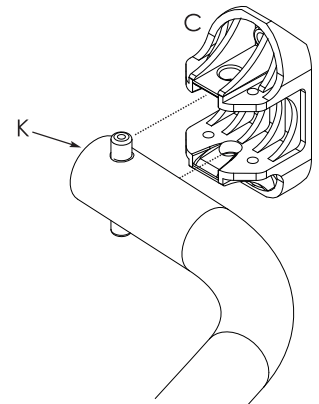

7 Screw in threaded pin screw(D) into pins on 1inch side until tight

Vissez les vis filetées dans les broches sur le côté 1 pouce jusqu'à ce que serré

Atornille los tornillos de pasador roscados en los pasadores en el lado de 1 pulgada hasta apretado

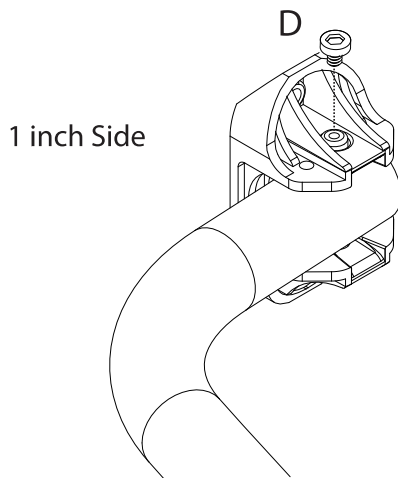

8 Screw in threaded pin screw(D) into pins on 7/8 inch side until tight

Vissez les vis à tige filetée dans les broches sur le côté 7/8 pouces jusqu'à ce que serré

Enrosque los tornillos de pasador roscados en los pasadores en el lado de 7/8 pulgadas hasta apretado

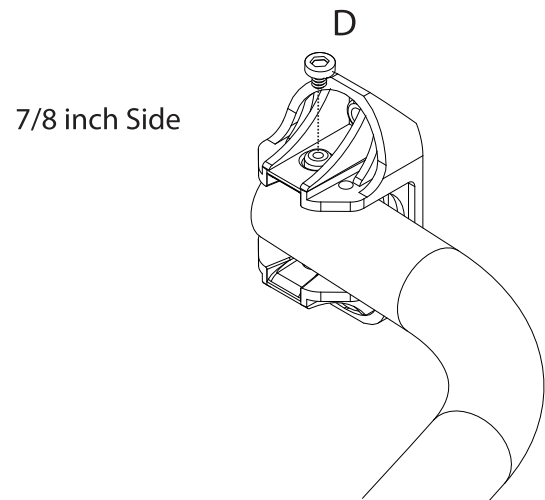

- 9 Tighten the 4 set screws on both brackets to level the rods.

Serrer les 4 vis de réglage sur les deux supports pour niveler les tiges.

Apriete los 4 tornillos de fijación en ambos soportes para nivelar las varillas.

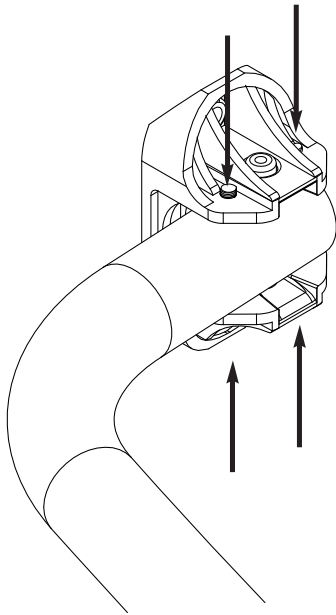

- 10 Attach decorative cover (A) using set screws (G) at the top and bottom using small allen wrench (I) as shown. Do this on both sides.

Fixer le couvercle décoratif (A) à l'aide des vis de fixation (G) en haut et en bas en utilisant une clé Allen (I) comme indiqué. Faites ceci des deux côtés.

Fije la cubierta decorativa (A) con los tornillos de fijación (G) en la parte superior e inferior usando una llave allen pequeña (I) como se muestra. Hacer esto en ambos lados.

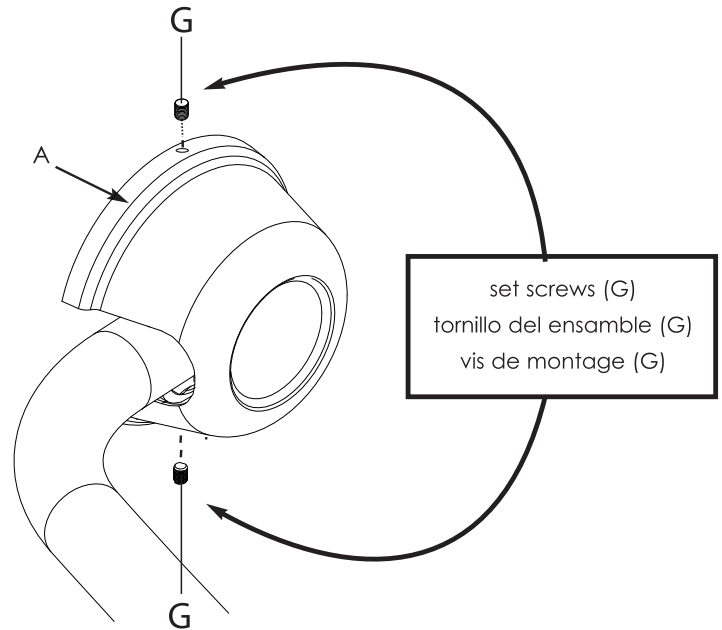

One Year Warranty on Jacuzzi® Branded Accessories

WARRANTY COVERAGE

Jacuzzi® Luxury Bath (“Company”) offers a one year warranty to the original purchaser (“user”) of a Jacuzzi® branded accessory for personal or single family residential use, subject to the following terms, conditions and limitations. The Company will repair or replace, at its sole option, the accessory or its component parts in accordance with the terms, conditions and limitations set forth in this limited warranty. Units in commercial use are excluded from any warranty coverage whatsoever. PLEASE READ THIS ENTIRE LIMITED WARRANTY, AS EXCLUSIONS AND CONDITIONS APPLY. All portions of the accessory are warranted against defects in material and workmanship for one year from date of purchase. This warranty does not apply to any display models or to any options or accessories not specifically mentioned herein. Warranty coverage begins on the date the unit was originally purchased by the user. The warranties provided by Company do not cover labor, and are parts only warranties.

The components referenced above and coverage of this warranty are for defects in material or workmanship, and not damage caused by installation, neglect, misuse, abuse, hard water conditions, optional equipment, the unit’s prior usage as an operational display, defects that should have been discovered before installation, or failure to follow the instructions and warnings set forth in the owner’s manual, including but not limited to cleaning of the accessory and its component parts, such as using chemicals, abrasives, acids, solvents, etc. Inspecting the unit prior to installation is the responsibility of the user, as well as the installer or building contractor who acts on behalf of the user. In the event of a problem, the unit must not be installed. The Company is not responsible for failures or damage that could have been discovered, repaired, or avoided by proper inspection and testing prior to installation. Damage occurring in transit is the responsibility of the carrier. Damage occurring to the unit during installation is the responsibility of the installer, building contractor and/or user, and damage occurring thereafter is the responsibility of the user. Any replacement parts shall be covered only by the original equipment manufacturer warranty, if any. The distributor, dealer and user are responsible for knowing local code requirements and notifying the installing contractor of these requirements at the time of purchase. The Company is not responsible for costs to modify any product to obtain any code approval, such as city, county, or state building codes in U.S.A. or federal, municipal, provincial or other codes in Canada and Mexico. To make a claim, user must first contact Company and thereafter return any part claimed to be defective within the warranty period to Company, freight prepaid. Proof of purchase (original sales receipt) from the original purchaser must accompany all warranty claims. Defects or damage caused by the use of other than genuine Company parts is not covered by this warranty.

IMPLIED WARRANTIES OF MERCHANTABILITY AND FITNESS FOR A PARTICULAR PURPOSE ARE DISCLAIMED ALTOGETHER OR TO THE FULLEST EXTENT ALLOWED BY LAW. This warranty takes the place of all other warranties, express or implied, in fact or at law, including implied warranties of merchantability and fitness for a particular purpose. Company reserves the right to use replacement parts that may be different from the part(s) that accompanied the original accessory, including but not limited to different in appearance, configuration, performance and/or structure. No agent, dealer, distributor, service company or other party is authorized to change, modify or extend the terms of this limited warranty in any manner whatsoever. In addition, **THE COMPANY WILL NOT BE RESPONSIBLE FOR INCIDENTAL OR CONSEQUENTIAL DAMAGES** or losses arising from any cause including but not limited to its own negligence. This exclusion applies even if Company was advised in advance of the possibility of such damages. This limited warranty does not include labor, transportation, or other costs incurred in the removal and/or reinstallation of the original unit and/or installation of a replacement unit; any costs relating to obtaining access for repair; or loss of use damage, including loss of sales, profit or business advantage of any kind under any circumstances. Accessories are excluded from any warranty coverage if any addition, deletion, or modification of any kind whatsoever has been made to the unit (or to any component). Warranty coverage is provided in the United States of America, Canada and Mexico only. The liability of Company under this limited warranty, if any, shall not exceed the original amount paid for the product claimed to be defective. Dated proof of purchase of accessory is required for a warranty claim. These disclaimers shall be equally applicable to any service provided by Company and its designated representatives.

The Company will provide the warranty service described above when the following conditions have been met: the failure is of the nature or type covered by the warranty; the user has informed an Authorized Jacuzzi® Luxury Bath Service Agent or Warranty Service Department Representative of the nature of the problem during the warranty period; conclusive evidence (e.g., dated proof of purchase) is provided to the foregoing by the user proving that the failure occurred or was discovered within the warranty period; and, an authorized independent service person or Company representative has been permitted to inspect the unit during regular business hours within a reasonable time after the problem was reported by the user. In order to obtain warranty service, contact Jacuzzi® Luxury Bath at: www.jacuzzi.com or Warranty Service Department, 14525 Monte Vista Avenue, Chino, California 91710, (800) 288-4002.

All replacement parts, equipment, and repairs shall assume the remaining warranty period of the part(s) replaced. The Company’s warranty obligation shall be discharged upon tender of replacement or repair. The customer’s refusal to accept the tender terminates the Company’s warranty obligation.

LEGAL RIGHTS: This Limited Warranty gives you specific legal rights. There are no warranties applicable to Jacuzzi® products except as expressly stated herein or as implied by applicable state and federal laws. You may also have other rights that vary from state to state. Some states do not allow limitations on how long an implied warranty lasts, disclaimer of certain warranties, or the exclusion or limitation of incidental damages, so some of the above limitations may not apply to you. Company will not be responsible for any statements or representations made in any form that go beyond, are broader than or are inconsistent with any authorized literature or specifications furnished by the Company.