



ITEM / ARTICLE / ARTÍCULO #MZ75827 Chrome
#MZ75826 Brushed nickel

Jacuzzi® is a registered trademark of Jacuzzi Inc. ©2017 Jacuzzi Inc. All rights reserved.

Jacuzzi® est une marque de commerce déposée de Jacuzzi Inc. ©Jacuzzi Inc, 2017. Tous droits réservés.

Jacuzzi® es una marca registrada de Jacuzzi Inc. ©2017 Jacuzzi Inc. Todos los derechos reservados.

FIDDICH™ BATHROOM FAUCET ROBINET DE SALLE DE BAINS GRIFO PARA BAÑO

Questions, problems, missing parts? Before returning to your retailer, call our customer service department at 1-800-288-4002, 9 a.m. - 8 p.m., EST, Monday - Friday.

Des questions, des problèmes, des pièces manquantes? Avant de retourner l'article au détaillant, appelez notre service à la clientèle au 1 800 288-4002, entre 9 h et 20 h (HNE), du lundi au vendredi.

¿Preguntas, problemas, piezas faltantes? Antes de volver a la tienda, llame a nuestro Departamento de Servicio al Cliente al 1-800-288-4002, de lunes a viernes de 9 a.m. a 8 p.m., hora estándar del Este.

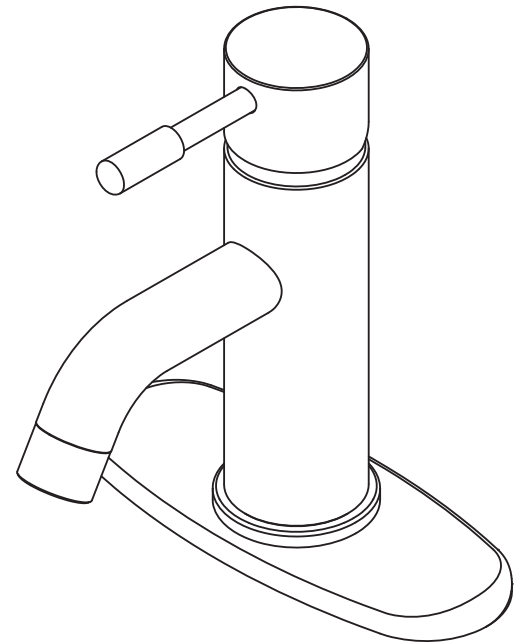

**ATTACH YOUR RECEIPT HERE /
JOIGNEZ VOTRE REÇU ICI /
ADJUNTE SU RECIBO AQUÍ**

Purchase Date / Date d'achat / Fecha de compra _____

HELPFUL TOOLS (NOT INCLUDED) / OUTILS UTILES (NON INCLUS) / HERRAMIENTAS ÚTILES (NO SE INCLUYEN)

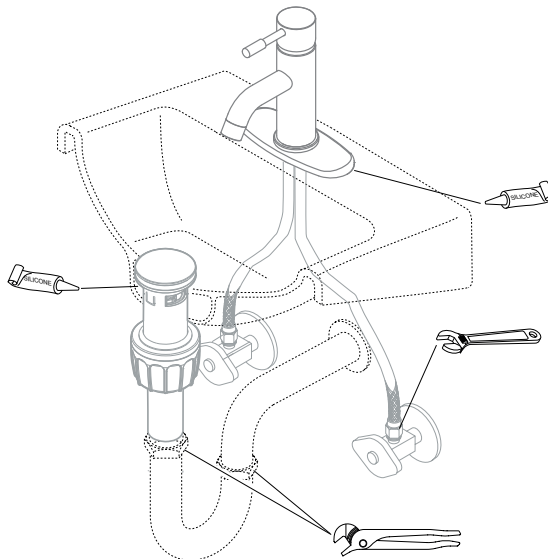

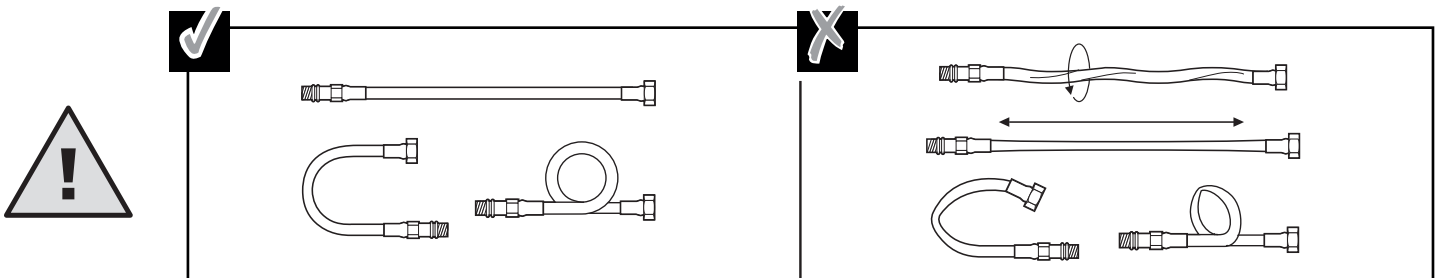
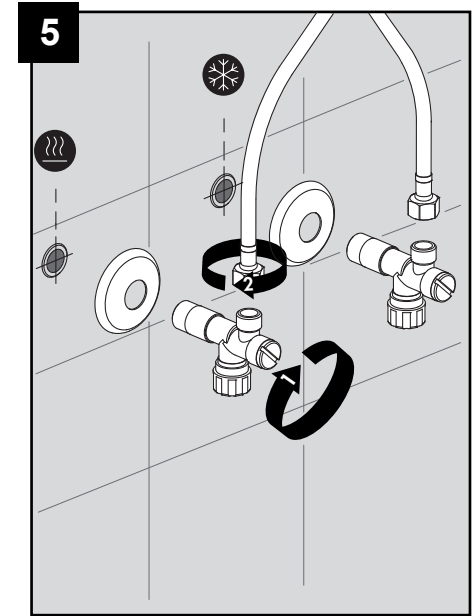
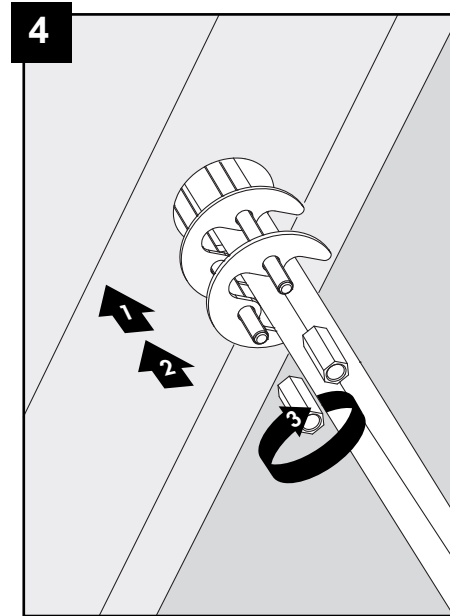
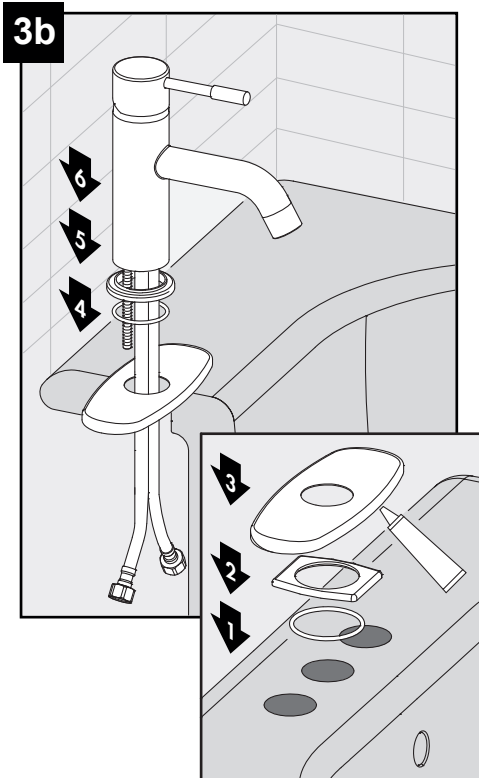
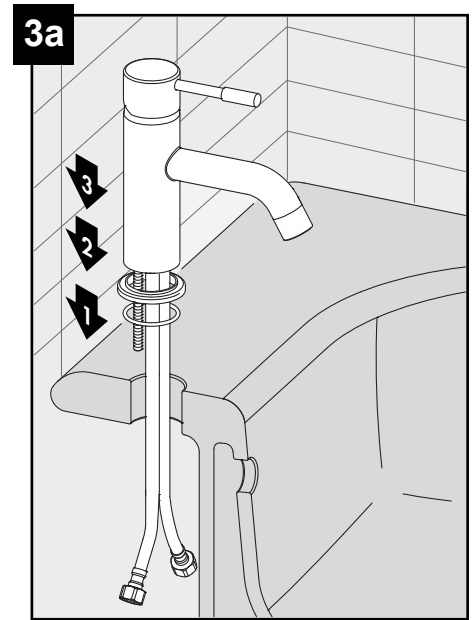
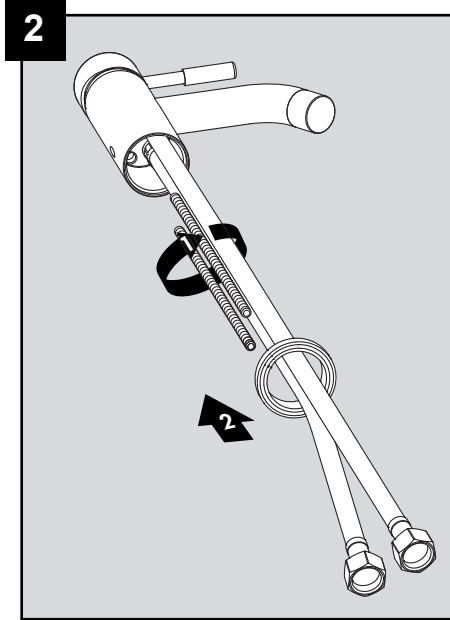
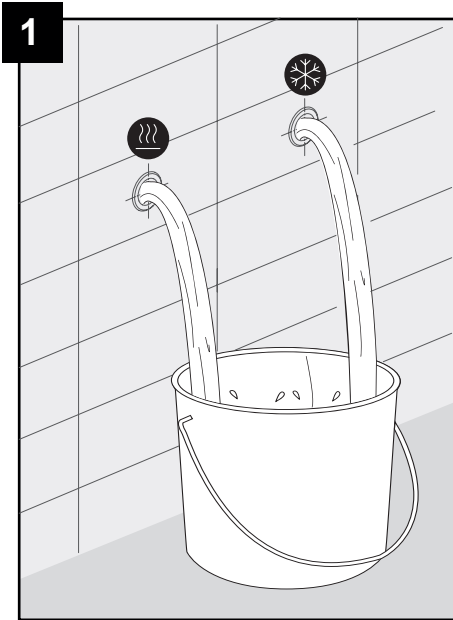

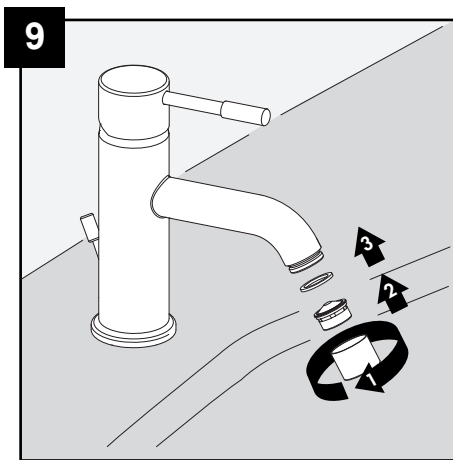
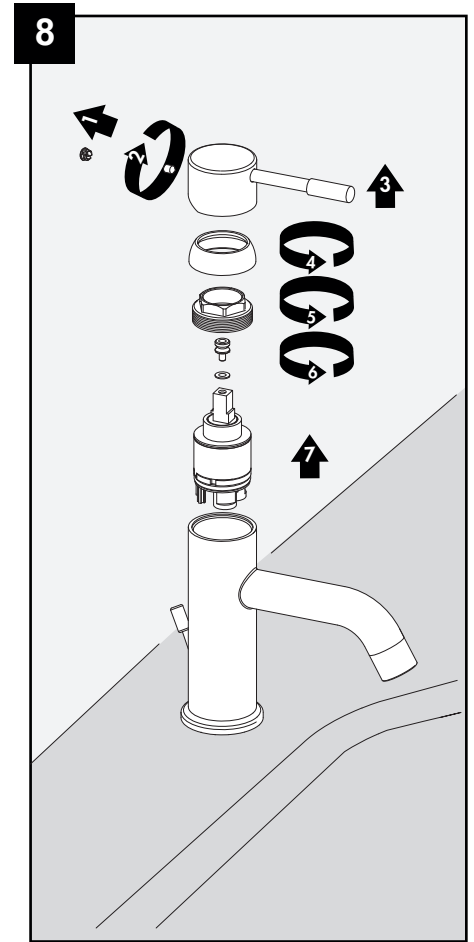
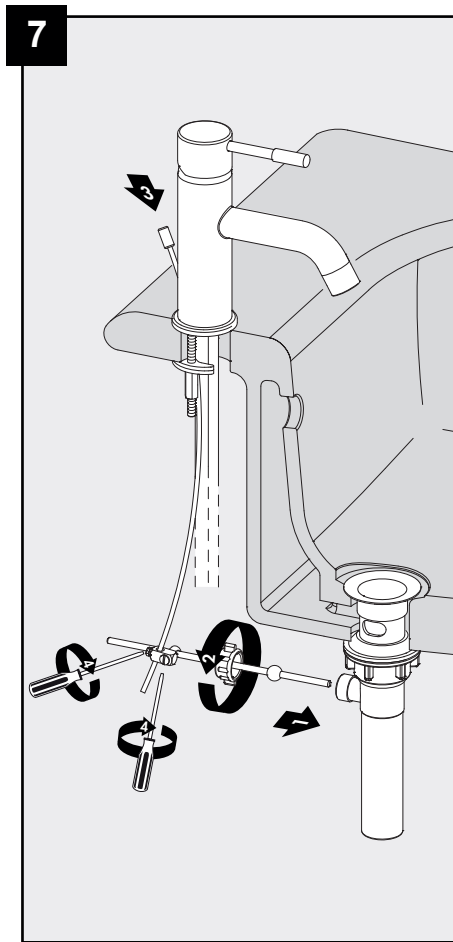
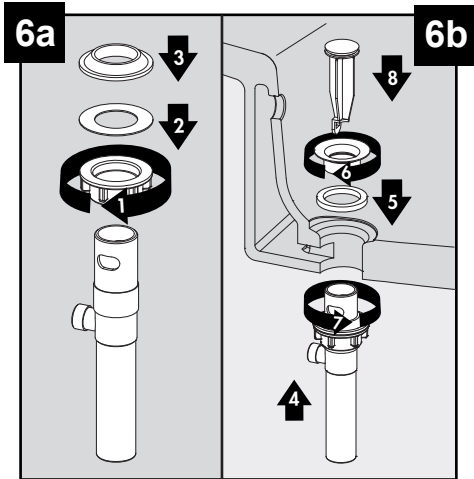

PROBLEM PROBLÈME PROBLEMA	POSSIBLE CAUSE CAUSE POSSIBLE CAUSA POSIBLE	CORRECTIVE ACTION MESURE CORRECTIVE ACCIÓN CORRECTIVA
<p>Leak from under handle.</p> <p>La poignée fuit.</p> <p>Goteo debajo de la llave.</p>	<p>Locking nut has come loose. O-ring on cartridge is dirty or damaged.</p> <p>L'écrou de serrage est desserré. Le joint torique de la cartouche est sale ou endommagé.</p> <p>La tuerca de retención está floja. El aro tórico en el cartucho está sucio o dañado.</p>	<p>Tighten the locking nut. Clean or replace O-ring.</p> <p>Serrez l'écrou de serrage. Nettoyez ou remplacez le joint torique.</p> <p>Aprieta la tuerca de retención. Limpia o reemplaza el aro tórico.</p>
<p>Aerator leaks or has an inconsistent water flow pattern.</p> <p>L'aérateur fuit ou donne un jet non fluide.</p> <p>Hay goteras en el aireador o el flujo de agua es irregular.</p>	<p>Aerator is dirty or misfitted.</p> <p>L'aérateur est sale ou mal installé.</p> <p>El aireador está sucio o mal colocado.</p>	<p>Remove aerator, check for debris in the aerator screens, and confirm the rubber washer is properly installed.</p> <p>Retirez l'aérateur, vérifiez si des débris se trouvent dans les filtres et assurez-vous que la rondelle en caoutchouc est correctement placée.</p> <p>Quita el aireador, verifica que no haya desechos en las mallas del aireador y que la arandela de goma está colocada correctamente.</p>

WARRANTY

Jacuzzi Luxury Bath (“Company”) offers a limited lifetime non-transferrable warranty to the original purchaser (“user”) of a Jacuzzi® branded Fiddich™ faucet (“Faucet”), for personal or single family residential use, subject to the following terms, conditions and limitations. The Company will repair or replace, at its sole option, the faucet or its component parts in accordance with the terms, conditions and limitations set forth in this limited warranty. Units in commercial use are excluded from any warranty coverage whatsoever. PLEASE READ THIS ENTIRE LIMITED WARRANTY, AS EXCLUSIONS AND CONDITIONS APPLY. The ceramic cartridge is warranted against defects in material and workmanship for the lifetime of the product. If at any time the cartridge fails, Company will provide a replacement cartridge or part, free of charge. All other portions of the Faucet are warranted against defects in material and workmanship for one year from date of purchase. This warranty does not apply to any display models or to any options or accessories not specifically mentioned herein. Warranty coverage begins on the date the unit was originally purchased by the user. The warranties provided by Company do not cover labor, and are parts only warranties.

The components referenced above and coverage of this warranty are for defects in material or workmanship, and not damage caused by installation, neglect, misuse, abuse, hard water conditions, optional equipment, the unit’s prior usage as an operational display, defects that should have been discovered before installation, or failure to follow the instructions and warnings set forth in the owner’s manual, including but not limited to cleaning of the Faucet and its component parts, such as using chemicals, abrasives, acids, solvents, etc. Inspecting the unit prior to installation is the responsibility of the user, as well as the installer or building contractor who acts on behalf of the user. In the event of a problem, the unit must not be installed. The Company is not responsible for failures or damage that could have been discovered, repaired, or avoided by proper inspection and testing prior to installation. Damage occurring in transit is the responsibility of the carrier. Damage occurring to the unit during installation is the responsibility of the installer, building contractor and/or user, and damage occurring thereafter is the responsibility of the user. Any replacement parts shall be covered only by the original equipment manufacturer warranty, if any. The distributor, dealer and user are responsible for knowing local code requirements and notifying the installing contractor of these requirements at the time of purchase. The Company is not responsible for costs to modify any product to obtain any code approval, such as city, county, or state building codes in U.S.A. or federal, municipal, provincial or other codes in Canada and Mexico. To make a claim, user must first contact Company and thereafter return any part claimed to be defective within the warranty period to Company, freight prepaid. Proof of purchase (original sales receipt) from the original purchaser must accompany all warranty claims. Defects or damage caused by the use of other than genuine Company parts is not covered by this warranty.

IMPLIED WARRANTIES OF MERCHANTABILITY AND FITNESS FOR A PARTICULAR PURPOSE ARE DISCLAIMED ALTOGETHER OR TO THE FULLEST EXTENT ALLOWED BY LAW. This Limited Warranty takes the place of all other warranties, express or implied, in fact or at law, including implied warranties of merchantability and fitness for a particular purpose. Company reserves the right to use replacement parts that may be different from the part(s) that accompanied the original Faucet, including but not limited to different in appearance, configuration, performance and/or structure. No agent, dealer, distributor, service company or other party is authorized to change, modify or extend the terms of this limited warranty in any manner whatsoever. In addition, THE COMPANY WILL NOT BE RESPONSIBLE FOR INCIDENTAL OR CONSEQUENTIAL DAMAGES or losses arising from any cause (e.g., water damage to carpet, ceiling, tiles, marble, loss of use, etc.) including but not limited to its own negligence. This exclusion applies even if Company was advised in advance of the possibility of such damages. This limited warranty does not include labor, transportation, or other costs incurred in the removal and/or reinstallation of the original unit and/or installation of a replacement unit; any costs relating to obtaining access for repair; or loss of use damage, including loss of sales, profit or business advantage of any kind under any circumstances. Faucet units are excluded from any warranty coverage if any addition, deletion, or modification of any kind whatsoever has been made to the unit (or to any component). Warranty coverage is provided in the United States of America, Canada and Mexico only. The liability of Company under this limited warranty, if any, shall not exceed the original amount paid for the Faucet or product claimed to be defective. Dated proof of purchase of Faucet is required for a warranty claim. These disclaimers shall be equally applicable to any service provided by Company and its designated representatives.

The Company will provide the warranty service described above when the following conditions have been met: the failure is of the nature or type covered by the warranty; the user has informed an Authorized Jacuzzi Luxury Bath Service Agent or Warranty Service Department Representative of the nature of the problem during the warranty period; conclusive evidence (e.g., dated proof of purchase) is provided to the foregoing by the user proving that the failure occurred or was discovered within the warranty period; and, an authorized independent service person or Company representative has been permitted to inspect the unit during regular business hours within a reasonable time after the problem was reported by the user. In order to obtain warranty service, contact Jacuzzi Luxury Bath at: www.jacuzzi.com or Warranty Service Department, 14525 Monte Vista Avenue, Chino, California 91710, (800) 288-4002.

All replacement parts, equipment, and repairs shall assume the remaining warranty period of the part(s) replaced. The Company’s warranty obligation shall be discharged upon tender of replacement or repair. The customer’s refusal to accept the tender terminates the Company’s warranty obligation.

LEGAL RIGHTS: This Limited Warranty gives you specific legal rights. There are no warranties applicable to Jacuzzi® products except as expressly stated herein or as implied by applicable state and federal laws. You may also have other rights that vary from state to state. Some states do not allow limitations on how long an implied warranty lasts, disclaimer of certain warranties, or the exclusion or limitation of incidental damages, so some of the above limitations may not apply to you. Company will not be responsible for any statements or representations made in any form that go beyond, are broader than or are inconsistent with any authorized literature or specifications furnished by the Company.

GARANTIE / GARANTÍA

Le fabricant garantit le robinet contre les défauts de matériaux ou de fabrication présents au moment de l'expédition de l'usine pendant une période limitée à compter de la date d'achat. Cette garantie ne s'applique qu'à l'acheteur initial. Le fabricant convient de corriger un tel défaut sans frais ou, à sa discrétion, de remplacer le robinet par un modèle comparable ou de qualité supérieure. Pour effectuer une réclamation au titre de la garantie, communiquez avec notre service à la clientèle au 1 800 288-4002 afin d'obtenir une autorisation de retour et des instructions d'expédition. Vous devrez peut-être présenter une copie de votre reçu comme preuve d'achat. Tous les frais de désinstallation et de réinstallation incombent à l'acheteur. L'acheteur est responsable de tout dommage causé au robinet à la suite d'un accident, d'un usage inapproprié ou d'une installation inadéquate, ou par l'ajout d'accessoires qui ne sont pas produits par le fabricant. Le fabricant n'est aucunement responsable de l'installation du robinet durant la période de garantie. Aucune autre garantie explicite n'est consentie. Le fabricant décline toute garantie implicite. Le fabricant n'est pas responsable des dommages accessoires, consécutifs ou spéciaux découlant de l'utilisation ou du rendement du produit, à l'exception de ce qui pourrait être prévu autrement par la loi. Cette garantie vous confère des droits précis. Il est possible que vous disposiez également d'autres droits, qui varient d'un État ou varient selon l'État ou la province où vous résidez. Cette garantie remplace toute garantie antérieure.

El fabricante garantiza que este grifo no presenta defectos en la mano de obra ni en los materiales presentes en el momento del transporte desde la fábrica durante un período limitado de por vida a partir de la fecha de compra. Esta garantía es válida sólo para el comprador original. El fabricante acepta reparar dichos defectos sin cargo o, según nuestro criterio, reemplazar el grifo por un modelo comparable o superior. Para obtener los servicios cubiertos por la garantía, llame a nuestro Departamento de Servicio al Cliente al 1-800-288-4002 para enviarle una autorización de devolución y las instrucciones de envío. Es posible que se le exija presentar una copia del recibo de venta como comprobante de compra. Todos los costos de extracción y reinstalación son de responsabilidad explícita del comprador. Cualquier daño al grifo producido por accidente, uso indebido o instalación incorrecta, o a causa del uso de elementos accesorios que no son del fabricante, será responsabilidad del comprador. El fabricante no asume ningún tipo de responsabilidad por la instalación del grifo durante el período de garantía. No existe otro tipo de garantía explícita. El fabricante rechaza cualquiera y todas las garantías implícitas. El fabricante no se hará responsable por daños accidentales, resultantes o especiales que surjan en relación con el uso o el funcionamiento del producto, excepto que la ley indique lo contrario. Esta garantía le otorga derechos legales específicos, pero podría tener también otros derechos que varían de estado/provincia a estado/provincia. Esta garantía sustituye cualquier garantía previa.

CARE AND MAINTENANCE / ENTRETIEN / CUIDADO Y MANTENIMIENTO

- Clean periodically with a soft cloth. Avoid abrasive cleaners, steel wool, and harsh chemicals as these will dull the finish and void your warranty.
- Nettoyez régulièrement le robinet avec un linge doux. N'utilisez pas de nettoyeur abrasif, de laine d'acier ni de produit chimique puissant; ceux-ci risquent de ternir le fini et leur utilisation annulera votre garantie.
- Limpie periódicamente con un paño suave. Evite utilizar limpiadores abrasivos, lana de acero y químicos agresivos, ya que pueden dañar el acabado y anular la garantía.

REPLACEMENT PARTS LIST / LISTE DES PIÈCES DE RECHANGE / LISTA DE PIEZAS DE REPUESTO

For replacement parts, call our customer service department at 1-800-288-4002, 9 a.m. - 8 p.m., EST, Monday - Friday.

Pour obtenir des pièces de rechange, veuillez communiquer avec notre service à la clientèle au 1 800 288-4002, entre 9 h et 20 h (HNE), du lundi au vendredi.

Para obtener piezas de repuesto, llame a nuestro Departamento de Servicio al Cliente al 1-800-288-4002, de lunes a viernes de 9 a.m. a 8 p.m., hora estándar del Este.

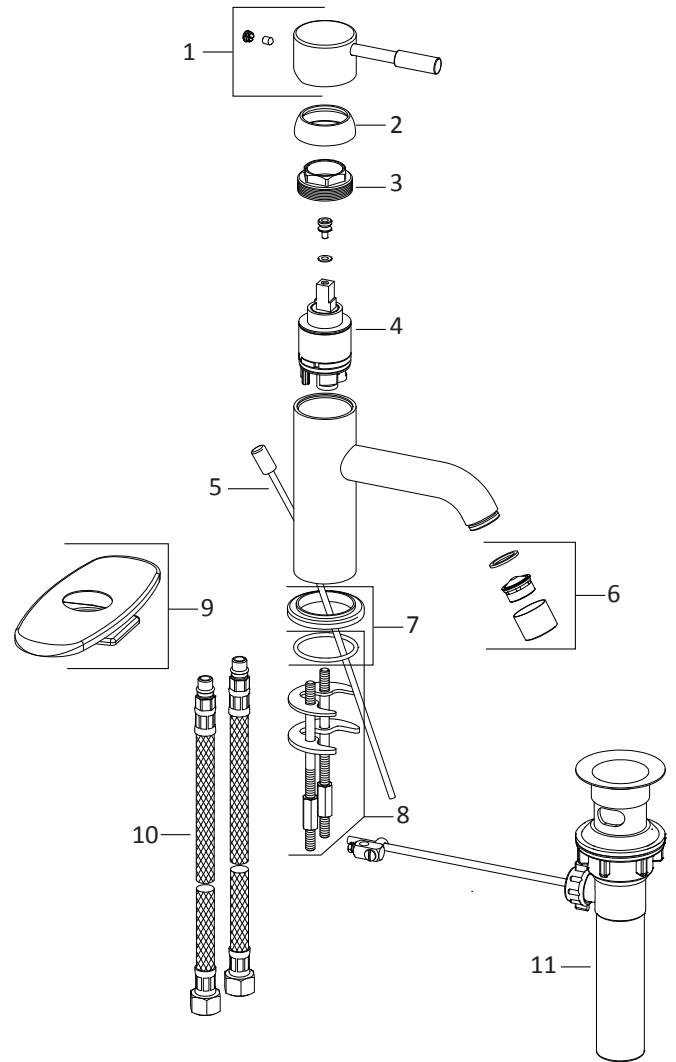

PART PIÈCE PIEZA	DESCRIPTION / DESCRIPTION / DESCRIPCIÓN	PART # / NO DE PIÈCE / PIEZA # MZ75826	PART # / NO DE PIÈCE / PIEZA # MZ75827
1	Metal Handle / Poignée en métal / Manija de metal	78CR910L2HC	78PW910L2HC
2	Trim Cap / Capuchon décoratif / Tapa del reborde	69CR954ABS	69PW954
3	Locking Nut / Écrou de blocage / Contratuerca	69CC954ABSA	69CC954ABSA
4	Ceramic Disc Cartridge / Cartouche à disque en céramique / Cartucho de disco de cerámica	53CC956GMD	53CC956GMD
5	Pop-Up Assembly / Dispositif de vidange à bonde / Conjunto levadizo	78CR911D	78PW911D
6	Aerator / Brise-jet / Aireador	78CR682B1/2	78PW682B1/2
7	Base Trim Ring / Garniture circulaire de base / Argolla ornamental e la base	78CR579R	78PW579R
8	Fixing Kit	78CC957	78CC957
9	Cover Plate & Putty Plate / Applique et plaque de mastic / Cubierta y placa de masilla	53CR962O	53PW962O
10	Flexible	78AE950/579LFB 78AE950/579LFR	78AE950/579LFB 78AE950/579LFR
11	Pop-Up	USCR944A	USPW944A

